



Revamping the Casale Way

by
F. Baratto
AMMONIA CASALE S.A.
Lugano, Switzerland



for presentation at the
AFA Workshop on
Enhancement of Production Efficiency
Alexandria, Egypt / 17-19 June 2008

Via G. Pocobelli 6
6900 Lugano
Switzerland
Tel +41.91.960.72.00
Fax +41.91.960.72.91/2
www.casale.ch
ammonia@casale.ch



AmmoniaCasale



CONTENT

1. FOREWORD
 - 1.1. Ammonia Casale Profile

2. PROPRIETARY TECHNOLOGIES
 - 2.1 Axial-Radial Catalytic Beds
 - 2.2 Secondary Reformer Burners

3. CASE HISTORIES
 - 3.1 Ultrafertil, Cubataõ, - Pre-Reforming Installation
 - 3.2 Al-Jubail Fertilizer Co. - Complete Plant Revamp
 - 3.3 PCS Nitrogen Trinidad, 03 Plant

4. CONCLUSIONS



ABSTRACT

For many years now, Ammonia Casale has been very actively dynamic in the field of ammonia plant revamping and has gained extensive experience in the design and implementation of complete plant revamping project and has successfully utilized this experience to satisfy a wide number of customers around the world. Most of these projects have included key modifications to reformers, machinery, ammonia converters and other equipment.

The unique Casale's ammonia plant revamp strategy has always focused on the development and application of new, advanced technologies to obtain the best possible improvements in plant performance at the lowest cost and a reduction in energy consumption, an increase in capacity, or a combination of the two is normally achieved.

The many Projects range from revamping of ammonia synthesis converters and their supply or the revamping of other special equipment, such as pre-reformers and shift converters, to the revamping of complete ammonia plants for capacity increase and energy conservation.

This paper presents some of the Casale technologies and a few case histories of the applications.

1. FOREWORD

Ammonia Casale is a company well-known for its know-how, design and in-depth technologies in the field of ammonia plant revamping and complete plant revamping projects. Among others, these include key modifications to ammonia converters, reformers, and other machinery and equipment.

Casale's unique policy has long been based upon the development and application of state-of-the-art advanced technologies for ammonia plant revamping, to get the best improvements in plant performance at the minimum cost. The performance enhancements encompass energy consumption reduction, capacity increase, or a combination of the both.

To attain this objective it is essential to identify the most critical items to improve for the best return. Ammonia Casale has done exactly that in very many projects and has developed and applied a number of proprietary improvements, which are presented below. The Projects undertaken range from the revamping of ammonia synthesis converters and the supply or revamping of other special equipment, such as pre-reformers and shift converters, to the revamping of complete ammonia plants to increase capacity and save energy.

Revamping the Casale way

presented at AFA Workshop on Enhancement of Production Efficiency - Alexandria, Egypt / 17-19 June 2008



2. 1. Ammonia Casale Profile

Ammonia Casale S.A. is one of the oldest companies active in the field of synthetic ammonia production, having been established in Lugano (Switzerland) in 1921 for the industrial development and commercialization of Dr Luigi Casale's inventions for the catalytic synthesis of ammonia.

Since the very beginning, and for many years now, Ammonia Casale has been active in the construction of new plants, with over 200 such plants built worldwide.

In the more recent past, activities were devoted to the revamping of existing plants, with more than 200 plants revamped in the last 23 years, and to the design of new plants. The company is still involved in new plant construction through its licensees.

At the present time, Ammonia Casale is a leader in the design of ammonia synthesis reactors and related process loops.

The company is also a leader in ammonia plant revamping, having its own technologies to upgrade synthesis loop and syngas front-end units.

Plant modernizations represent a very important aspect of Ammonia Casale's support to clients aiming at increasing plant capacity or reducing energy consumption to within limits where the installation of much additional new equipment would entail substantial investment costs. This is achieved by boosting efficiency of key equipment (e.g. reactors), by partial or total replacement of the old internals with new ones, or by "in situ" modifications. Based on prevailing raw material and energy costs, the return on investment is usually high.

The company can also claim the most experience in the comparison of uses of various different commercially available catalysts, and is in a position to guarantee optimal reactor performance with all these catalysts.

The main strength of Ammonia Casale lies in the licensing of its technologies. Most of the technologies are developed in house by a team of very specialized and experienced people. Thanks to the innovative trend set by founder Dr Luigi Casale, plus the heritage and background of subsequent management teams, Ammonia Casale invested significantly in technology development.

During the last few decades this discipline evolved from an empirical art, with an intuitive sense for good design, into a more rationalized activity.

Process design is now supported by sound insight into the chemistry of the processes, catalyst behaviors, kinetic data, heat and mass transfer phenomena, fluid mechanics, science of construction materials, and cost analysis.

Revamping the Casale way

presented at AFA Workshop on Enhancement of Production Efficiency - Alexandria, Egypt / 17-19 June 2008



Ammonia Casale Technical Services avail themselves of specialists in all the above fields, as well as of sophisticated tools for investigating, analyzing and picturing complex phenomena in a way unachievable with ordinary skilled manual calculations. The process design is based on advanced computer-aided techniques with applications ranging from process flow-sheeting to kinetics, to fluid dynamics simulations and mechanical stress analysis.

In addition to the technology, Ammonia Casale can also provide all services required for the completion of a project, from engineering right down to construction, start-up and operation of the plant.

2. PROPRIETARY TECHNOLOGIES

2.1. Axial-Radial Catalyst Beds

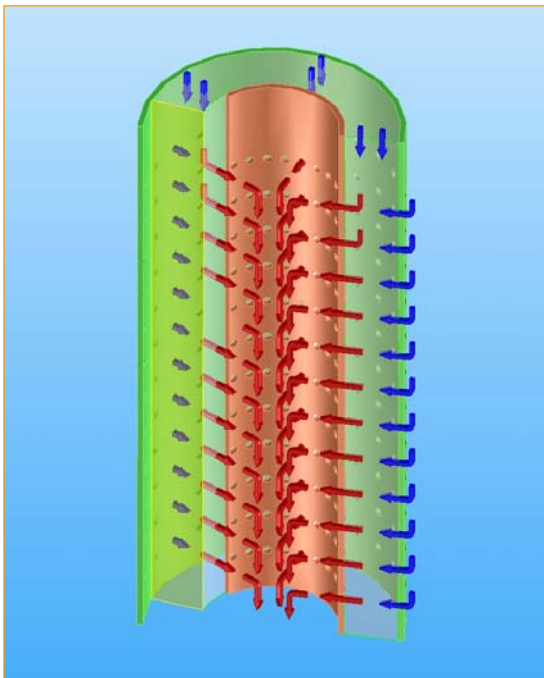

Fig. 1: Gas Distribution in an Axial-Radial Catalyst Bed

The axial-radial catalyst bed is the base of most of the technologies used by CASALE in catalytic reactors.

In an axial-radial catalyst bed most (about 90%) of the gas passes through the catalyst bed in a radial direction, resulting in much lower pressure drop than in an axial-flow catalyst bed. The balance passes down through a top layer of catalyst in an axial direction, thus eliminating the need for a top cover on the catalyst bed (Fig. 1).

Mechanically the bed is very simple, being made only of two vertical perforated walls and of one bottom closure plate. The absence of a top cover greatly simplifies and facilitates the construction of the converter internals, allowing at the same time the full utilization of the catalyst volume.

Also catalyst loading and unloading is very easy, as the axial-radial bed is completely open on the top granting an easy access to the bed even for small-diameter vessels, while for unloading there are drop out pipes provided at the bottom.

The materials used for its construction varies according to the application.

The essential advantages of the axial-radial catalyst bed concept are the same wherever in the ammonia plant it is applied, namely:

- low pressure drop;
- use of small-size catalyst.

Revamping the Casale way

presented at AFA Workshop on Enhancement of Production Efficiency - Alexandria, Egypt / 17-19 June 2008



Casale makes maximum use of the axial-radial bed concept, in all catalytic reactors.

This technology was developed for ammonia converters and later applied to shift converters and pre-reformer reactors, since it was demonstrated as being flexible, economical and efficient. Outside the ammonia field, it has also been applied in methanol and formaldehyde synthesis reactors. To date Casale has put more than 500 axial-radial beds into successful service.

Here follows a brief description of each application in the ammonia field.

2.1.1 Ammonia Synthesis Converter

The ammonia converter is one of the most critical items when planning a revamp for energy saving or capacity increase, and in most cases it is the first item to be revamped thanks to the relatively low cost and very high return.

AMMONIA CASALE is very active in this field and has introduced fundamental innovations in the converter design and revamping, such as the "in-situ" modification of bottle-shaped converters such as the Kellogg ones, and the three-bed intercooled configuration that is being used by CASALE for over ten years now.

This activity has been very rewarding and now AMMONIA CASALE has more than 160 converters on stream, out of which about 80 are "in-situ" modifications, and about 40 are three-bed intercooled converters (new or revamped) with full bore opening.

The most important ingredients for this success are the axial-radial beds, described above (see figure 1), and the three-bed configuration, both adopted for revamping of any kind of converters and for new reactors as well.

AMMONIA CASALE has recently introduced into the market the next generation of ammonia reactors, the pseudo-isothermal plate-cooled converters. Three of these converters are already on-stream.

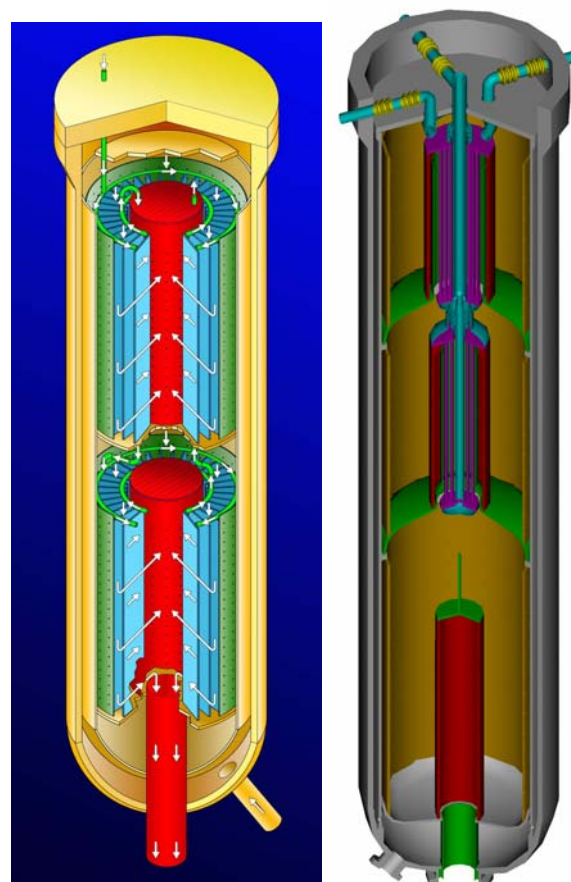

Fig. 2:
Plate-cooled and 3-bed ammonia converter



2.1.2 Pre-Reforming Reactor Technology

The pre-reforming reactor proposed by AMMONIA CASALE is designed according to the axial-radial technology for catalyst beds, taking advantage from the peculiarities of this design: minimum pressure drop and use of more active and poison resistant small-size catalyst.

The utilization of this reactor enables part of the primary reforming reaction to be carried out (about 10%) outside the primary reformer, enabling the increase of the capacity of the existing unit, as well as the reduction of the size of the reformer to be implemented in new plants.

Another advantage of the pre-reformer is that it transforms all higher hydrocarbons to methane, and performs part of the reforming reactions, thus producing some hydrogen. These two actions enable the increase of the preheating temperature of the process gas, and also the reduction of the steam carbon ratio, therefore reducing the energy consumption of the primary reforming section.

2.1.3 Shift Converters

The new design developed by Ammonia Casale is based on the use of the axial-radial catalyst bed, described above, and can be applied both to revamping and to new converters.

The new axial-radial configuration has an inherently low pressure drop of the catalyst bed, and this makes it possible to use small-size, more active and more resistant to poisons catalyst.

The new design also has the following additional features:

- protection of catalyst from water droplets carried over from secondary reformer heat recovery train or others;
- possibility to load different volumes of catalyst with no mechanical modifications;
- easy operation.

In case of application to existing plants, the existing shift converters can be easily transformed to axial-radial design by introducing new vertical perforated walls, which are cylindrical and form the inlet and outlet walls, in prefabricated sectors that are assembled inside the existing converter vessel.

The advantages achievable with this revamping are the low pressure drop with consequent energy saving, the low pressure drop also helps eliminating the hydraulic constraints having more flow through the front end, allowing for higher plant throughput.



2.2. Secondary Reformer Burner and Autothermal reformer

Ammonia Casale makes an advanced design for the secondary reformer burner available, through its sister company Casale Chemicals S.A. The Casale Advanced Secondary Reformer Burner achieves the following goals:

- low pressure losses in both air and primary reformer streams (<1 bar in the air stream);
- low temperature of the burner surfaces exposed to the flames;
- superior mixing in the flame;
- reduced flame length, avoiding catalyst impingement even at high operating loads
- soot-free combustion;
- homogeneous gas composition and temperature distribution at catalyst bed entrance;
- protection of the refractory lining from the hot core of the flame.

Introducing this design into an existing plant reduces the pressure loss in the process air, thus increasing the air compressor capacity and/or reducing its energy consumption. On account of the very even gas composition at the surface of the catalyst bed and the greater amount of the reaction that has already taken place in the top space of the reactor, it is possible to obtain greater service life from the catalyst and/or to reduce the catalyst volume.

Casale burners are in use in seven ammonia plants and six more are being installed.

Casale has also a proprietary design for autothermal reformers, achieving essentially the same advantages highlighted here above. In this case burner tip is water cooled, ensuring longer expected life for this highly critical piece of equipment. Casale autothermal reformer is already in operation in 2 ammonia plants and 4 methanol plants.

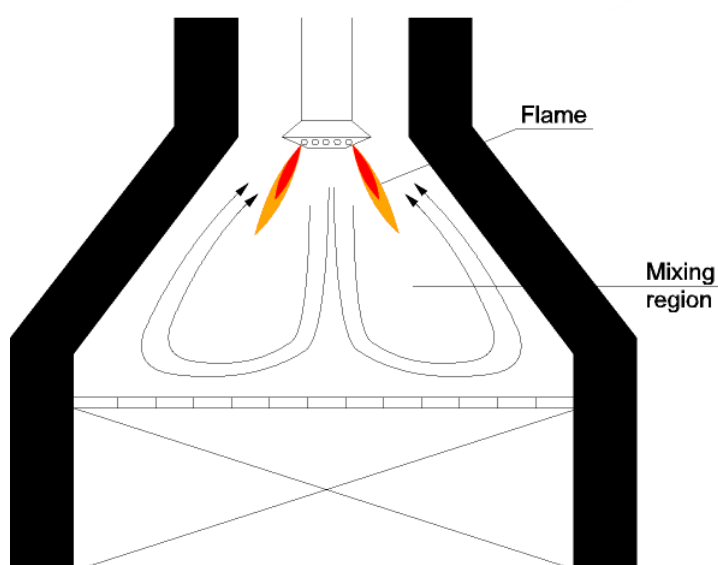

Fig. 3: Casale design for secondary reformer burner



2.3. Ammonia Wash System

The Ammonia Washing Unit removes water and carbon dioxide from the syn gas before entering the loop. Carbon oxides in synthesis gas are almost completely removed by the CO₂ Removal and Methanation sections, while some moles of water still remains in make-up gas and they could poison ammonia converter catalyst decreasing its performances.

The Ammonia Wash System takes advantage of the ammonia-water/carbon dioxide reciprocal solubility to completely remove them from make-up gas. The oxygenated compounds (H₂O and CO₂) are completely dissolved in the liquid ammonia; thanks to the Casale patented ejector, the unit is designed exploiting the differential pressures between the liquid ammonia and make-up gas in order to optimize the nebulization of liquid ammonia and allow an intimate contact between the two phases.

Due to the fact that undesired compounds have been removed, syngas can be fed directly to the ammonia converters, without crossing the ammonia chilling section.

Summarizing, the expected benefits from the installation of AMMONIA CASALE AWU, are the following:

- Reduction of synthesis gas compressor overall energy consumption, thanks to a better performance given by lower suction temperature at the H.P. casing inlet.
- More favorable conditions for ammonia condensation within the chilling section, since the ammonia concentration in the converter effluent stream is no more reduced by the make-up gas mixing (reduction of energy consumption in the refrigeration compressor).

2.4. Specific know-how

Besides these proprietary technologies, Ammonia Casale has specific know-how in all the critical sections of an ammonia plant:

- Primary reforming
- CO₂ removal section
- Air compressor debottlenecking
- Cryogenic gas cleaning

This knowledge is applied in all the revamping jobs in order to find the best solution to remove plant bottlenecks.



3. CASE HISTORIES

3.1. Ultrafertil, Cubatão – Pre-Reformer Installation

Ultrafertil, a fertilizer company in Brazil and an existing client of Ammonia Casale, has an ammonia plant based on steam reforming technology at Cubatão, Brazil, fed by both refinery off-gas and naphtha. Originally designed for a capacity of 450 t/d, the plant was operating at about 520 t/d at the time the revamp project was determined.

The flow rate and composition of the off-gas fluctuated considerably as a result of changes in feedstock, load and product range in the refinery. To safeguard the primary reformer from the ill effects of a possible sudden increase in the carbon content of the feedstock, it had to be operated at a very high steam : carbon ratio.

The client requested Ammonia Casale to find the best revamping options for increasing the plant capacity in two stages, first to 600 t/d and then to 800 t/d, while reducing energy consumption and phasing out the use of naphtha as feedstock on account of its cost.



Fig. 4: The Recently installed Pre-Reformer

The single most beneficial choice seemed to be to install a pre-reformer to stabilize the composition of the gas entering the primary reformer and to reduce the duty on the primary reformer. To attain the first capacity increase target (600 t/d), the reforming furnace burners were replaced, some alterations were made to the reforming furnace heat recovery train and a new, high-efficiency ammonia converter with Casale axial-radial technology was installed. The converter was completely replaced because the pressure shell of the old one was extensively cracked and could no longer be considered safe. This phase of the work was completed in July 2001. The performance of the pre-reformer and the new synthesis converter are shown in Tables 1 and 2.



Table 1: Pre-Reformer Performance		
	<i>Process Guarantees</i>	<i>Test-Run</i>
Conversion of C ₂ H ₆ , %	>85	98.7
Conversion of C ₃₊₁ , %	>95	100

Table 2: Synthesis Loop Performance		
	<i>Process Guarantees</i>	<i>Test-Run</i>
Converter Capacity, t/d	600	> 616
NH ₃ at 3 rd bed outlet, %	15.8	> 16.08
Converter pressure drop, bar	2.8	2.8

The second phase of the work (expansion to 800 t/d) comprised replacing the reformer tubes, revamping the shift converters, CO₂ removal system and the feed gas, air and synthesis gas compressors, and installing a new purge gas recovery unit. Minor changes to the heat exchangers, pumps and piping were also planned.



Fig. 5: The three new converters and the HP waste heat boilers

Revamping the Casale way

presented at AFA Workshop on Enhancement of Production Efficiency - Alexandria, Egypt / 17-19 June 2008



3.2 Al-Bayroni Fertilizer Co., former Samad

In 2002 Ammonia Casale completed the revamp of a 1,000-t/d (original capacity) ammonia plant based on Kellogg technology at the Al-Bayroni Fertilizer Company, located in Al-Jubail, Kingdom of Saudi Arabia. This plant originally started up in March 1983. It uses natural gas for both feed and fuel.

The plant had been revamped once before in 1989 by replacement of the converter internals with a traditional two-bed one-interchanger design, (not a Casale design) and installation of a membrane-type hydrogen recovery unit, which allowed it to operate at a capacity of about 1,170 t/d.

The main goal of the project was to increase production capacity to 1,300 t/d. Further targets were energy saving, reducing cooling water consumption and improving reliability.

A second step of capacity increase was also considered, meanwhile the natural gas quality of the Al-Bayroni plant has considerably changed with a higher content of nitrogen. Casale adapted their studies on plant production and efficiency improvement to the new design basis. All the new equipment had therefore to be designed for the highest capacity.

An important requirement was the very tight project schedule. The project started in October 2000. All the engineering and procurement services for the de-bottlenecking project were completed in September 2001. A turnaround took place in January 2002, and all modifications were made during the period of a standard shut-down. Start-up followed immediately after.

Since every modification to machinery is very expensive, and since it would have been quite uneconomic to reharp reformer because the existing tubes were almost new, Casale prepared a minimum-investment revamping option according to the following guidelines:

- Main rotating equipment would not be revamped or replaced;
- No modifications would be made to the primary reformer section;
- Modifications to the equipment had to be suitable for the further capacity expansion;
- Possible variations in natural gas quality had to be considered;
- The plant should be able to operate at original capacity when new sections were isolated;
- Possible trips in new sections should not trip the existing plant.

The capacity expansion was limited to 1,300 t/d by the suction capacity of the existing synthesis gas compressors.

The feed gas desulphurization, feed gas compression, secondary reformer and methanation sections were suitable for the new operating conditions and needed no modifications.

The following modifications were implemented:



Pre-reforming and Primary Reforming

The primary reformer of the Samad ammonia plant is a typical Kellogg top-fired unit with 416 catalytic tubes arranged in eight rows. The reformer tubes were replaced in 1997 with new HK40 tubes identical in every respect with the original tubes.

Without upgrading the reformer tubes the heat flux to the primary reformer could be increased only marginally. Therefore, to increase the capacity of the reformer up to the level needed for the capacity expansion, the steam : carbon ratio had to be decreased. On account of the high concentration of higher hydrocarbons in the natural gas, this could only safely be done by installing a pre-reformer. (Fig. 6).

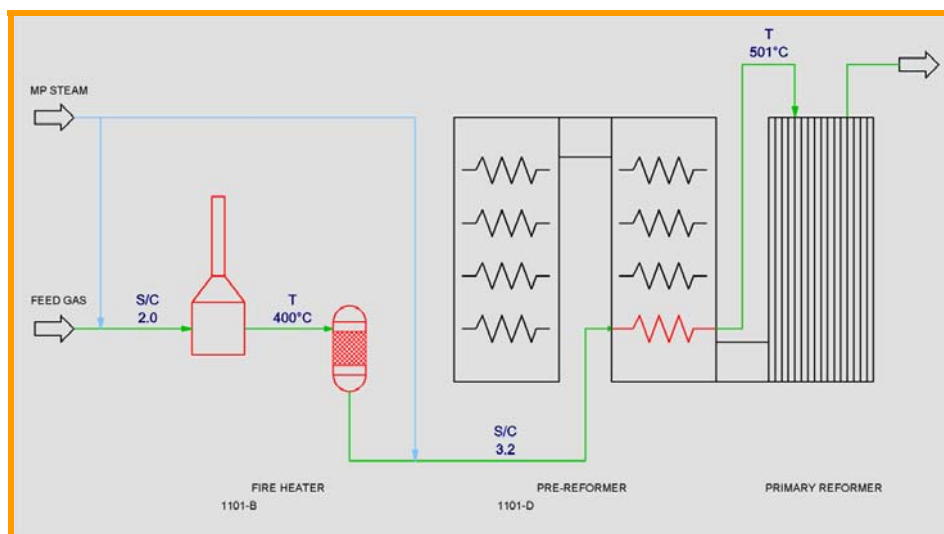

Fig. 6: New Fired Heater and Pre-Reformer

The advantages of the use of the pre-reformer and of the fired heater can be summarized as follows:

- the S/C ratio could safely be reduced;
- every possible change in natural gas composition could be accommodated.

Process Air

This section was designed to provide sufficient process air for a production of 1,000 t/d of ammonia under normal conditions. Any increase in plant capacity therefore required debottlenecking of this compressor. This was accomplished by the following main modifications:

- addition of an air booster driven by a back-pressure steam turbine;
- addition of an after-cooler downstream the new air booster;

The booster was sized to be able to accommodate the prospective future major expansion up to 1800 MTD.

Revamping the Casale way

presented at AFA Workshop on Enhancement of Production Efficiency - Alexandria, Egypt / 17-19 June 2008



Shift Conversion

The high pressure drop in the shift converters (0.5 bar in the HTS and 0.6 bar in the LTS for new catalysts; and >1.0 bar each for the aged catalysts for both reactors) was due to the axial-flow design of these converters. Retrofitting with Casale axial-radial internals reduced the pressure drop to about 0.3 bar, correspondingly increasing the suction pressure of the synthesis gas compressor. This pressure increase was very important to allow this machine to achieving the higher capacity without any modification to the make-up stages.

The advantages that resulted from this revamping can be summarized as follows:

- lower pressure drop;
- lower CO slip and thus lower inerts concentration in the make-up gas for the whole Campaign;
- longer catalyst life;
- catalyst protection against water droplets.

CO₂ Removal

The carbon dioxide removal system was an inhibited MEA system. The CO₂ content of the purified gas was satisfactorily low (around 120 ppm) but corrosion problems were observed. For the revamp the BASF aMDEA process was adopted by means of a simple solvent swap. None of the equipment needed modification. This change reduced the specific energy consumption, making it possible to reduce the S/C ratio.

Synthesis Loop

The reduction of the steam / carbon ratio and the revamping of the shift converter internals allowed an increase in plant throughput without appreciably increasing the system pressure drop. To allow the synthesis loop to handle the increased flow new **synthesis converter internals** were provided. The existing cartridge was a two-bed inter-cooled design installed in the 1989 revamp. This was replaced by a new three-bed axial-radial cartridge with one quench inlet between the first and second beds and one interchanger between the second and third beds. The greater conversion efficiency and lower pressure drop of the new converter internals meant that both the required gas recycle rate and the energy needed to drive it round the system were reduced, so the **recirculator wheel** of the main compressor was replaced by a new one designed for the revised flow conditions. The spare energy, resulting from the reduced recirculation power requirement, provided the additional power needed to maximise the discharge pressure of the make-up gas compression stages at the increased suction flow rate without any other modification to the compressor or its turbine drive.

On account of the better converter performance and higher loop operating pressure, not only the ammonia concentration but also the temperature at the converter outlet was higher. The latter was above the design value for the metallurgy of the existing converter outlet pipe and for the boiler feed water preheater, so both were replaced.

Revamping the Casale way

presented at AFA Workshop on Enhancement of Production Efficiency - Alexandria, Egypt / 17-19 June 2008



The improved performance of the synthesis loop significantly reduced the specific chiller duty, allowing the plant capacity increase to be borne by the refrigeration compressor and its steam driver without any modification.

Table 3 compares the performance of the plant before and after the revamp.

Table 3: Al-Bayroni Plant Performance Before and After Revamp		
	<i>Before revamp</i>	<i>After revamp</i>
Production, t/d	1170	1312
Specific energy consumption, Gcal/tNH ₃		about 6 % reduction
Sea water consumption, m ³ /tNH ₃		about 7 % reduction



3.3 PCS Nitrogen Trinidad, O3 Plant

The O3 ammonia plant is an original C.F. Braun design that was constructed in 1965 in Brea California. The plant was relocated to Trinidad in 1994. The design capacity at that time was 680 MTD. Some minor modifications increased the plant's production rate to 753 MTD.

Following a recent plant revamp engineered by Ammonia Casale, the plant production is now 953 MTD, while the energy consumption is now 9.7 Gcal/MT. The revamp involved converting the plant from the original Braun purifier design operating with 50% excess air in the front end, to a conventional ammonia plant operation. The purifier was idled and a hydrogen recovery unit was installed to treat the purge gas from the synthesis loop. The two existing converters were retrofitted with Casale isothermal design converter baskets. These are the first of their kind to be installed in ammonia service. They provided reduced pressure drop and improved conversion.

Revamp Scheme

The Braun process is characterized by the introduction of excess air in the secondary reformer. This reduces the load of the primary reformer and requires a cryogenic purifier, downstream of the methanator, to remove the excess nitrogen. This purifier removes almost all of the inerts contained in the gas. There is however, an expander located immediately upstream of the purifier and this creates a large pressure drop.

Therefore, the two main areas that needed to be improved were the reforming section and the synthesis loop.

The following major changes were required for the revamp:

1. Installation of a Pre-reformer.
This was comprised of:
 - a. A reactor with Casale designed axial-radial internals.
 - b. A new fired heater to recover the resulting temperature drop
2. Revamp of the Primary Reformer Involving:
 - a. Replacement of the catalyst tubes.
 - b. Extension of the radiant section.
 - c. Replacement of the mixed feed coil.
 - d. Installation of a combustion air blower to supplement the gas turbine exhaust (GTE).
3. Installation of a quench nozzle on the HTS quench.
4. Upgrade of the CO₂ removal system.
This comprised:
 - a. Replacement of the trays in the MDEA Regenerator.
 - b. Installation of an additional steam reboiler.

Revamping the Casale way

presented at AFA Workshop on Enhancement of Production Efficiency - Alexandria, Egypt / 17-19 June 2008



- c. Installation of two additional Regenerator Overhead Condensers.
 - d. Installation of an additional Regenerator Overhead Condenser.
5. Idling of the Purifier section.
 6. Replacement of the synthesis gas compressor HP rotor.
 7. Replacement of the existing two converter internals with the Casale isothermal basket design. This consists of an arrangement of exchanger plates in the axial-radial catalytic beds.
 8. Installation of a BFW heater.
 9. Installation of a Hydrogen Recovery Unit.
This is a used unit that was refurbished and was handled as a joint effort between Air Products and PCS Trinidad.
 10. Changes in the ammonia recovery section.
 - a. Replacement of the MP ammonia absorber with a high pressure absorber.
 - b. Installation of a new HP Absorber feed pump.
 11. Replacement of the ammonia product pumps.
This was handled as an internal project at PCS.
 12. Replacement/Addition of control valves and PSVs.

Process Details

Pre-Reforming

The pre-reformer section was installed to increase the total reforming capacity of the plant.

The pre-reformer is an Ammonia Casale designed axial-radial adiabatic reactor loaded with a nickel based steam reforming catalyst. Its low pressure drop, of approximately 0,40 bar, is characteristic of the axial-radial design.



The gas leaving the pre-reformer is partially reformed. It then flows to the fired heater, which supplies the heat necessary to increase the temperature to the reformer tube inlet temperature.

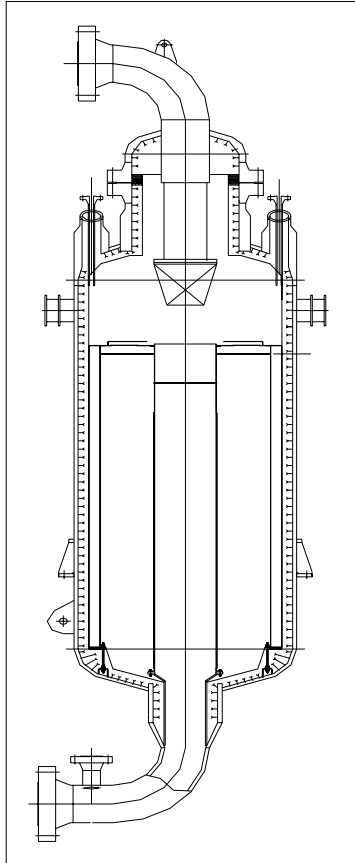

Fig. 7 - PCS Axial-Radial Pre-Reformer

Primary Reformer

The primary reformer was an original Foster Wheeler design side-fired reformer. The tubes were at their end-of-life and the frequent failures were causing severe plant reliability issues. The major changes were:

- Tube arrangement changed from staggered to inline.
- Number of tubes increased
- Extension of the radiant box.
- Installation of additional burners.
- Replacement of the old burner tips.
- Replacement of the mixed feed coil.

Revamping the Casale way

presented at AFA Workshop on Enhancement of Production Efficiency - Alexandria, Egypt / 17-19 June 2008

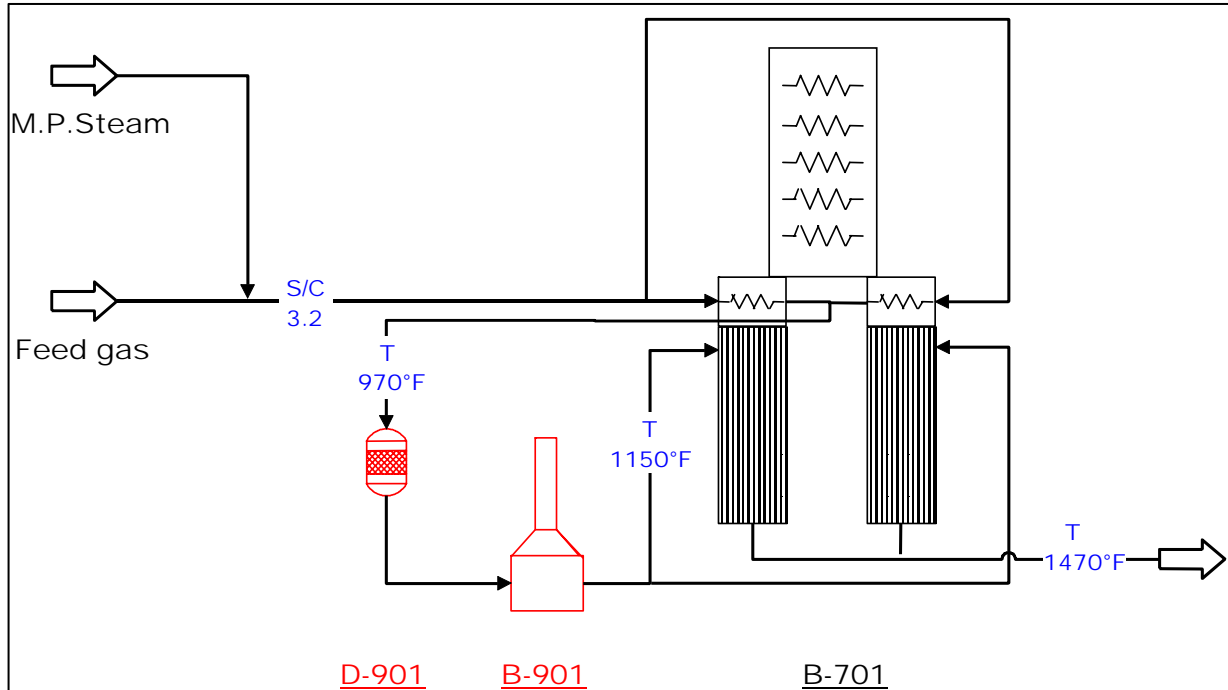

Fig. 8 - Pre-Reformer Arrangement, new items in red.

The radiant box extension was shipped in sections with insulation pre-installed, ready for assembly. The insulation however was damaged in shipping and was replaced on site.

The composition of the fuel gas to the burners was changed with the elimination of the waste gas from the purifier section. The gas from the HRU is much less and the burner tips were changed as a result. The gas turbine exhaust, which supplies oxygen to the burners, was deemed to be insufficient and an auxiliary air blower was installed to supplement the oxygen supply. The exhaust of this blower was tied into the GTE ducting.



Fig. 8 – Photo of the Primary Reformer and Fired Heater

Shift Conversion

The shift converters, both HTS and LTS, were found to be adequate for the revamp and the only change made in this section was the installation of a BFW quench system to control the HTS inlet temperature. This was necessary because of the limitation of the secondary reformer waste heat boiler.

CO₂ Removal

In reviewing the CO₂ removal system the key parameter used for design was the specific energy consumption, the revamp sought to maintain this at the old rates. To do so, an additional demand was required. This was supplied by installing an additional steam reboiler. In keeping with the increase in reboiler duty, the capacity of the MDEA Regenerator Overhead Condensers had to be increased. This was achieved by installing an additional cooler.

To maintain stripping efficiency, the MDEA strength was increased and the circulation rate was increased. The system hydraulics was reviewed and it was necessary to replace the MDEA Regenerator trays with new high efficiency design trays.

Synthesis Gas Compressor

The LP stage of the compressor was found to be suitable to the capacity increase. This was primarily due to the significant increase in suction pressure, caused by the decommissioning of the purifier section.

The HP stage was limiting with the increased volumetric flow and had to be retrofitted. A new rotor was installed.



Synthesis

The plant is fitted with two ammonia converters operating in parallel. The revamp of the synthesis section demanded a very significant efficiency improvement because of:

- The large capacity increases and
- The higher concentration of inerts in the circulating gas due to the front-end transformation.

This entailed the retrofit of the converter internals with Ammonia Casale isothermal design. This new design allowed a significant reduction in the circulation flow and consequently a considerable decrease in the specific duties of the exchangers. The lower recycle flow resulted in a smaller heat recovery in the synthesis waste heat boiler. To overcome this, a BFW pre-heater was installed. Additionally, the increased ammonia conversion in the synthesis loop translated into no additional load on the refrigeration system, which in turn meant no modification to the refrigeration compressor.

The Isothermal Ammonia Converter (IAC) design abandons the use of multiple adiabatic catalyst beds, commonly used in the ammonia industry for the pseudo isothermal design, and offers a higher conversion per pass. The new design is based on the use of plates immersed in the axial-radial catalyst bed to remove the reaction heat while it is formed.

As indicated in the diagram above, the temperature profile achieved in the catalyst bed follows the line of maximum reaction rate, so obtaining the highest possible conversion per pass from a given catalyst volume.

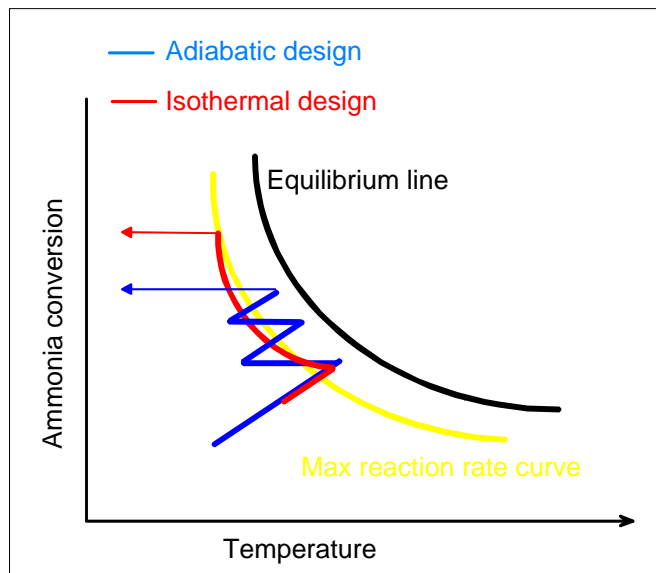

Fig. 9 - Temperature Profile of the IAC.

The use of plates for cooling, allows the design of a pseudo isothermal converter without tubesheets, eliminating the size restriction and simplifying the construction of the internals and the operation of catalyst loading and unloading. In addition, the non-adiabatic beds are axial-radial, featuring a low pressure drop and allowing the use of small size, high activity catalyst.



Fig. 8 - Photo of the Converter Basket being lifted into place

Purge Gas Treatment

With the change in front end operating philosophy, the concentration of inerts in the loop was significantly increased, resulting in a much higher purge gas flow from the loop. To recover the hydrogen in the purge, a Hydrogen Recovery Unit, HRU, has been installed. The hydrogen product is recycled back to the synthesis gas compressor and the rejected or waste gas is used for dryer regeneration and sent to the primary reformer burners as fuel.



Fig. 9 - Photo of the Refurbished HRU

Steam System

HP steam generation has increased, but no equipment modifications were necessary.

Revamping the Casale way

presented at AFA Workshop on Enhancement of Production Efficiency - Alexandria, Egypt / 17-19 June 2008



CONCLUSIONS

The cases described here above are only examples of the different and possible schemes of the modifications that can be applied to any ammonia plant to improve the performances thereof.

The Casale approach is to customize the revamping to the real needs of the plant by taking into proper consideration the age of the equipment and its problem, in order not only to improve plant performances, but also to solve some drawbacks due to “ageing” in order to extend the plant life.

Lugano, April 2008

Revamping the Casale way

presented at AFA Workshop on Enhancement of Production Efficiency - Alexandria, Egypt / 17-19 June 2008



Lugano, April 2008

Code:paper/conf/amm/afa/afaworkshop june 2008

Revamping the Casale way

presented at AFA Workshop on Enhancement of Production Efficiency - Alexandria, Egypt / 17-19 June 2008